



**Built-in microwave drawer**

**MW 420**

- Built-in microwave drawer, perfect for kitchen islands, under counter and wall applications
- Can be installed perfectly flush in any standard depth cabinetry
- Handleless microwave drawer. One touch to open and close.
- Sensor cooking mode for easy cooking
- 950 Watts microwave power
- Net volume 1.2. cu.ft.

MW 420 620 ▾  
Stainless steel

▾ Available April 2014

Oven interior dimensions:  
W 17 5/16" x H 7 1/8" x D 16 9/16"  
Appliance dimensions:  
W 23 7/8" x H 16 9/16" x D 23 3/8"

**Cooking modes**  
10 Cooking modes, including melt, soften, keep warm.

**Operation**  
One touch to open and close the microwave drawer.

**Features**  
Glass touch control panel and an interactive visual display. Digital display with scrolling text. Interior capacity accommodates 9" x 13" pans and cups up to 7" in height or 20 oz. Adjustable cooking time up to 99 minutes and 99 seconds. Keep warm setting allows food to be kept warm for up to 99 minutes. Sensor cooking mode controls humidity and automatically adjusts cooking level and cooking time. Quick defrost program. Sensor reheat program. Popcorn sensor cooking. Kitchen Timer. Maximum microwave output power 950 Watts.

**Safety**  
Control panel lock.

**Planning notes**  
The built-in microwave drawer can be installed using a standard or flush (inset) installation (see adjacent drawings). Cabinet base support requirements: 100 pounds. Microwave drawer can be installed below an oven but requires a clearance of at least 2".

**Rating**  
Total rating: 0.95 kW  
Total Amps: 15  
120 V / 60 Hz  
Plan for a 48" connection cable with grounding plug.

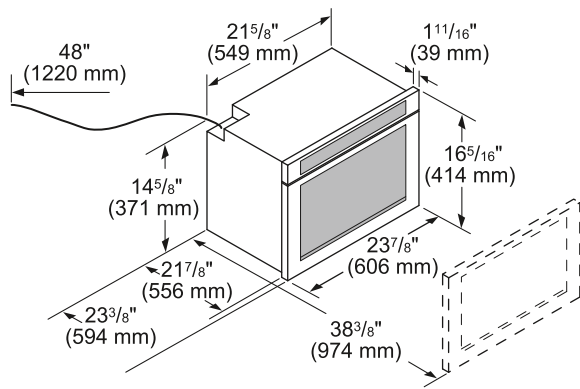

**Flush installation**

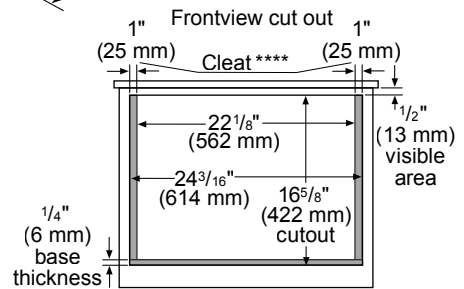
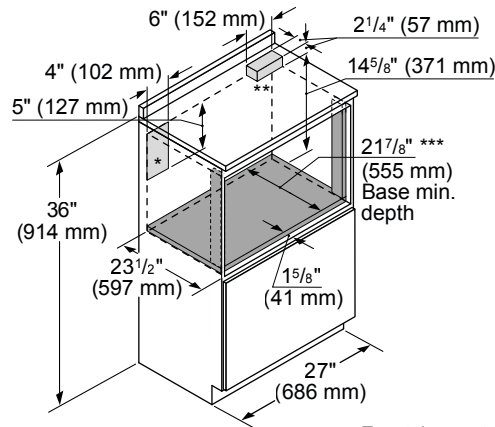

**Standard installation**

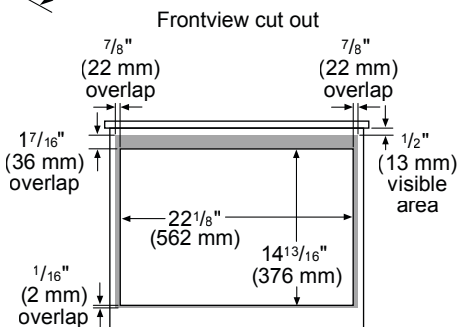
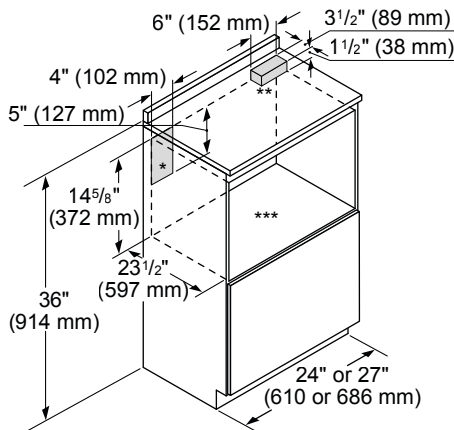

- \* Suggested location of electrical outlet
- \*\* Anti-Tip Block
- \*\*\* Base should support up to 100 lbs.
- \*\*\*\* Sides should be finished and extend back to cleat. Cleats should also be finished, as they may be visible after installation.

Numbers indicated inside parenthesis ( ) = mm