



CX 482 610

Stainless steel frame
Width 30" (80 cm)

Included accessories

1 Cooking sensor for temperature regulation in pots.

Installation accessories

In combination of several Vario cooktops, connecting strips must be used. Choose respective VA 420 strip from one of the below, depending on type of installation.

VA 420 000

Connection strip for combination with other Vario 400 series for flush mounting.

VA 420 010

Connection strip for combination with other Vario 400 series for surface mounting.

Optional accessories

CA 060 600

Cooking sensor for temperature regulation within pots.

GN 232 110

Teppan Yaki plate made of multi-ply material, 13" x 21", GN 1/1.

For full surface induction cooktops.

GN 232 230

Teppan Yaki plate made of multi-ply material, 13" x 14", GN 2/3.

For full surface induction cooktops.

Vario 400 series full surface induction cooktop

CX 482

- One large cooking surface
- Free positioning of up to 5 items of cookware
- All sizes and formats of cookware can be used
- TFT touch display for an intuitive control of all functions
- Cooking sensor function for temperature control in pots
- Professional cooking functions
- Max. power output of up to 5,500 W for large cookware
- Precision-crafted 3 mm stainless steel
- For surface-mounting with a visible edge or for flush mounting
- Can be combined with other Vario 400 series appliances

Cooking zones

One unique cooking surface allows for all sizes and formats of cookware to be used.

Up to 5 items of cookware can be placed simultaneously on the cooktop.

Operation

Easy to use color graphic TFT touch display with use indications.

Electronic power control in 17 output levels.

Features

Cooking sensor function.

Professional cooking function.

Dynamic cooking function.

Teppan Yaki function.

Booster function for pots.

Booster function for pans.

Keep warm function.

Individual pot detection.

Cooking timer for each cooking position.

Short-term timer.

Information key with use indicators.

Power management.

Cooktop-based ventilation control (with suitable hood).

Home network integration for digital services (Home Connect) wireless via WiFi. The use of the Home Connect functionality depends on the Home Connect services, which are not available in every country.

For further information please check: home-connect.com.

Safety

Main switch.

Residual heat indicator.

Child lock.

Safety shut-off.

Pause function.

Planning notes

Depending on the type of installation (surface-mounted or flush-mounted), the specific definition of the cut-out must be observed.

If combining several Vario 400 series appliances, a connection strip VA 420 must be placed between the appliances. Depending on the type of installation, the corresponding connection strip must be provided.

The weight bearing capacity and stability, in the case of thin countertops in particular, must

be supported using suitable substructures. Take into account the appliance weight and additional loads. Additional instructions for flush mounting:

Installation is possible in countertops made of stone, synthetics or solid wood. Heat resistance and watertight sealing of the cut edges must be observed. Concerning other materials please consult the countertop manufacturer.

The groove must be continuous and even, so that uniform placing of the appliance on the gasket is ensured.

Do not use discontinuous lining.

The joint width may vary due to size tolerances of the combinations and of the countertop cut-out.

Please read additional planning notes on pages 108 – 113.

If installing several appliances in individual cut-outs allow for a division bar of minimum 2" (50 mm) between the individual cut-outs.

Operates with magnetic (induction) iron pots and pans only. For an optimal heat distribution, the use of flat bottom cookware is recommended.

The wok pan WP 400 001 cannot be used with this appliance.

Intermediate shelf is recommended, but should be removable for customer service needs.

Appliance can be snapped into the countertop from above.

Appliance weight: approx. 68 lb. (30.8 kg).

Please read the installation details regarding air ducting on page 147.

Rating

Total rating: 7.4 kW.

Total Amps: 30 A.

208/220–240 V / 60 Hz

Plan for a 37" connecting cable without plug (hardwire required).

Surface-mount Installation

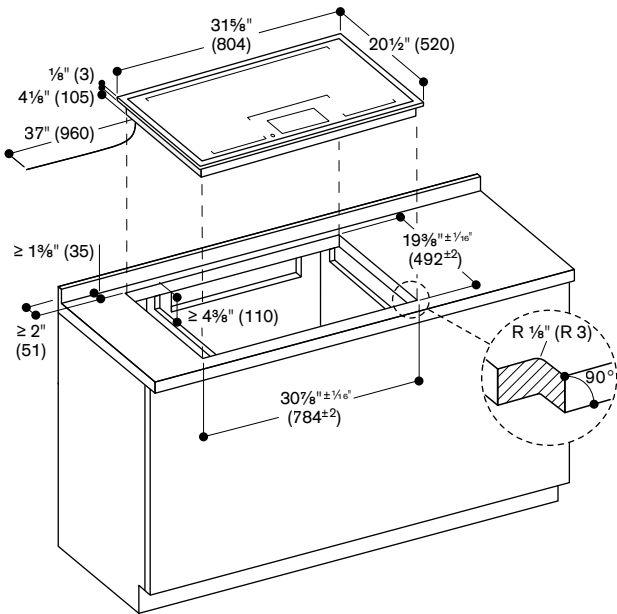

Flush-mount Installation

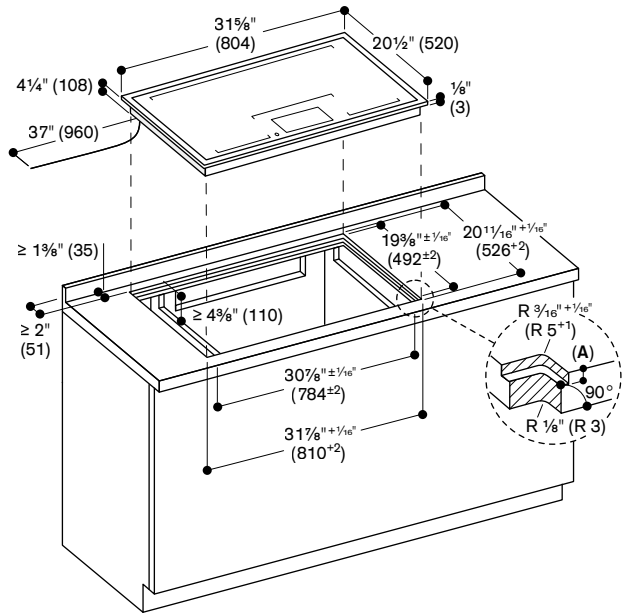

A: 1/8" (3.5^{0.5})

View from above

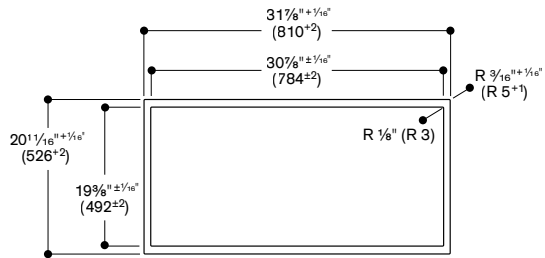

Longitudinal section

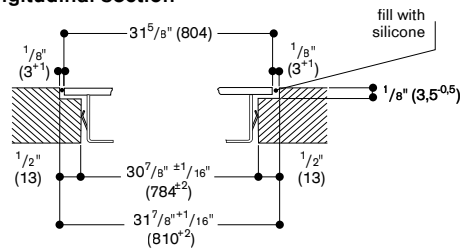

Cross section

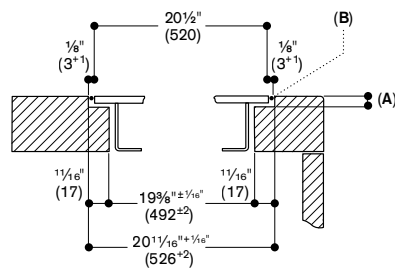

A: 1/8" (3.5^{0.5})
B: Fill with silicone