



AF 210 761

Stainless steel handle bar

Width 24" (60 cm)

Air extraction/Air recirculation

AF 210 791

Stainless steel handle bar

Width 36" (90 cm)

Air extraction/Air recirculation

Installation accessories

AA 210 460

Lowering frame for 24" AF visor hood, enables hood to disappear behind cabinetry.

AA 210 490

Lowering frame for 36" AF visor hood, enables hood to disappear behind cabinetry.

AA 210 491

Mounting set for 36" upper cabinet. Required for installation of 36" AF visor hood if AA210490 lowering accessory isn't used.

Optional accessories

AA 210 110

1 activated charcoal filter with high efficient odor reduction. For use with air air recirculation module AA211812.

AA 211 812

Patented air air recirculation module including 1 activated charcoal filter with high efficient odor reduction. For air recirculation.

Refer to page 196 for detailed information on the recirculation and lowering frame accessory.

Installation accessories for the air recirculation ducts can be found starting on page 194.

200 series Visor hood

AF 210

- Unobtrusive visor hood design thanks to integrated glass panel in the steam screen
- Especially quiet operation thanks to integrated sound insulation
- Especially high air output
- Dimmable, warm white LED light for ideal illumination of the entire cooktop
- The patented lowering frame allows the visor hood to disappear completely into the upper cabinet
- Air extraction or air recirculation system
- Air recirculation module with activated charcoal filter: quiet and highly efficient air recirculation solution with odor reduction as in air extraction mode and long replacement intervals

Output

Performance and noise level, output level 3/Intensive:

500 CFM

Sound level min. 49 dBA / max. 75 dBA intensive mode.

Features

Controls at front.

3 electronically controlled power levels and 1 intensive mode.

Automatic function with sensor-controlled run-on function.

Grease filter saturation indicator.

Stainless steel grease filter, dishwasher-safe.

Warm white LED light (3,600 K), continuously dimmable.

Lamp output 2x 9 W / 3x 9 W.

Illuminance 548 / 441 lx.

Light can be switched on separately.

Fan technology with highly efficient, brushless DC motor (BLDC).

Integrated sound insulation for quiet operation.

The blower is activated when the steam screen is extended.

Patented technology for extension of the steam screen.

Extendable steam screen up to 7 13/16".

Airflow-optimized interior for efficient air circulation and ease of cleaning.

Patented easy mounting system for simple installation.

The package includes a one-way flap.

Planning notes

No mounting set required for 24" AF 210 visor hood. For 36" AF 210 visor hood AA210491 mounting set is required. When lowering frame for 36" AF 210 visor hood is used, mounting set is not required.

A flexible duct (Part # 00361093) is needed when installed with lowering frame.

Patented air recirculation module with activated charcoal filter can be installed in the upper cabinet. The activated charcoal filter can be changed from the front by simply pulling out the filter.

The door of the upper cabinet must be fully open in order to exchange the activated charcoal filter.

To be installed in an upper cabinet without base.

The required cavity depth of the upper cabinet together with the lowering

frame measures 13 3/16".

The required cavity height of the upper cabinet together with the lowering frame measures 23 5/8".

Minimum clearance above gas cooktops 25 1/2". If the instructions for installation for the gas cooktop specify a greater distance, this must be adhered to.

Minimum clearance above induction cooktops 17".

Rating

Total rating: 430 W

Total Amps: 10 A.

120 V / 60 Hz

Connecting cable 35.4" with plug.

Measurement drawing of 24" AF visor hood

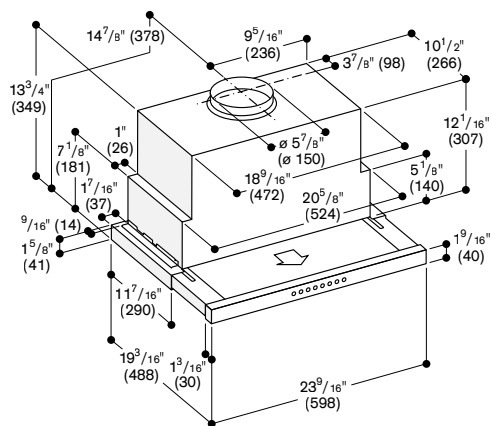

Measurement drawing of 36" AF visor hood

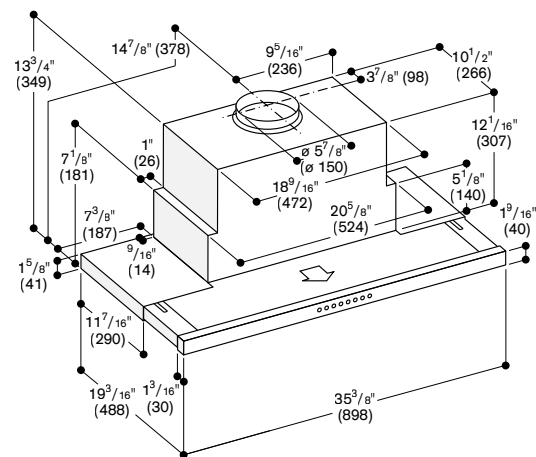

Cross-section of upper cabinet with AA 211 812 air recirculation module and lowering frame AA 210 490/460

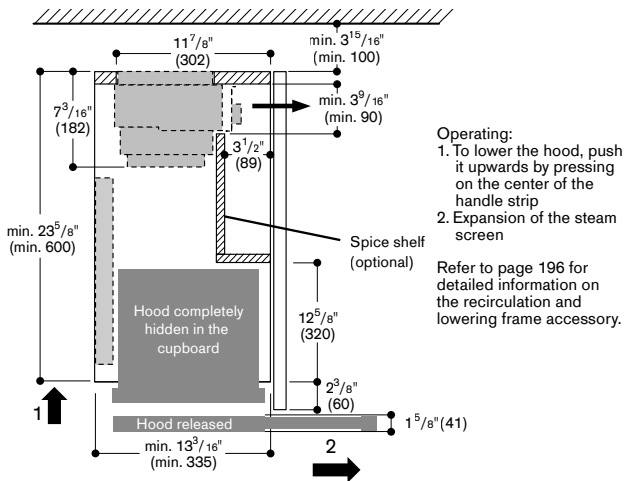

Cross-section of upper cabinet with AA 211 812 air recirculation module

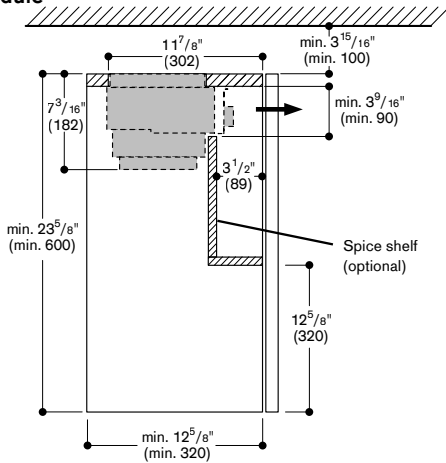

View from above of upper cabinet with AA 211 812 air recirculation module

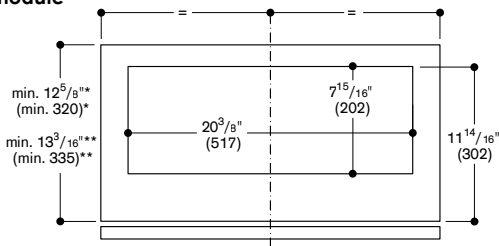

* only appliance
** Appliance with lowering frame AA 210 490/460

AA 211 812 air recirculation module

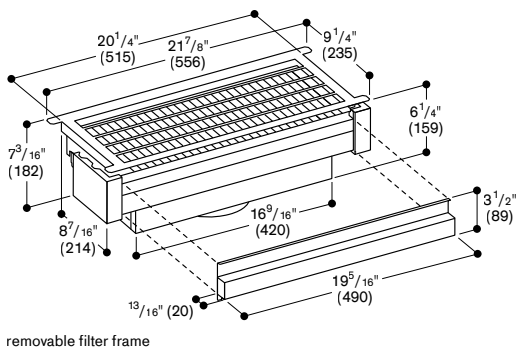

removable filter frame

Numbers indicated inside parenthesis () = mm

Upper cabinet for AF visor hood with lowering frame AA 210 460/ AA 210 490

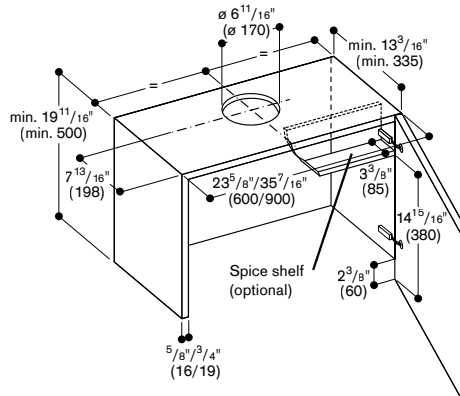

Upper cabinet for 24"/36" AF visor hood

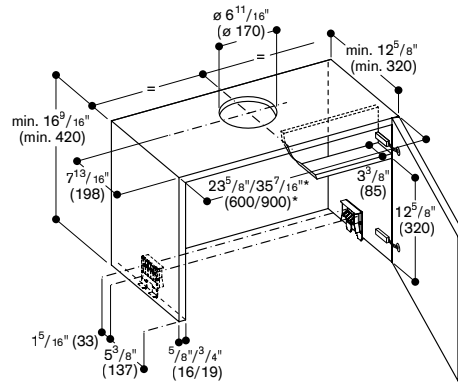

* for a 36" (90 cm) upper cabinet the mounting set AA 210 491 is required

Upper cabinet for 36" AF visor hood with AA 210 491 mounting set

