



Freezer column

RF 463

- Stainless steel interior
- Integrated automatic ice maker with fixed water connection
- Illuminated dispenser for ice cubes, crushed ice and chilled water
- Solid aluminum door bins
- Net volume 12 cu.ft.
- ENERGY STAR® qualified
- Star-K certified

Operation

Electronic precision temperature control with digital temperature display.

Technical features

Dynamic cool air distribution with Multi-Flow Air System.
Automatic defrosting with defrost water evaporation.
Energy-saving vacation mode.
Open-door and malfunction warning system.

Freezer compartment

No-frost technology with fast freezing.
Temperature adjustable from 7°F to -9°F (-14°C to -25°C).
4 solid metal shelves, two of which are manually adjustable.
2 fully extendable drawers with transparent front, one of which is large, one is regular.
Bright interior lighting with LED sidewall pillars.
One gallon door bin.
1 door bin with transparent front flap.

Ice and water dispenser

Illuminated ice and water dispenser.
Integrated, with fixed water connection.
Ice maker can be switched off independently.
Ice cube production approx. 4.2 lbs. (1.9 kg)/24 h.
Ice cubes and crushed ice.
Removable ice storage bin with approx. 6.6 lbs. (3 kg) capacity.
Chilled water supply approximately 1.3 quarts.

Planning notes

Flat hinge.
Door opening angle of 115°, optional 90° door stop.
Max. door panel weight 50 lbs.
Requires custom toe-kick.
Shut-off valve for water connection must be planned next to the appliance and always be accessible.
If the water pressure exceeds 116 psi, connect pressure relief valve between water tap and hose set.
Cold water connection required.
Electrical location 6" above ground in lower left corner of unit.
Water pressure 29 to 116 psi.

For details, please refer to the refrigeration planning guide on pages 167-183.

Consumption data

Energy consumption 1.425 kWh/24h.; annually: 520 kWh.
Noise level 39 dB.

Rating

Total rating 0.565 kW.
Total Amps: 15 A.
120 V / 60 Hz
Connecting cable 78 3/4" with plug.

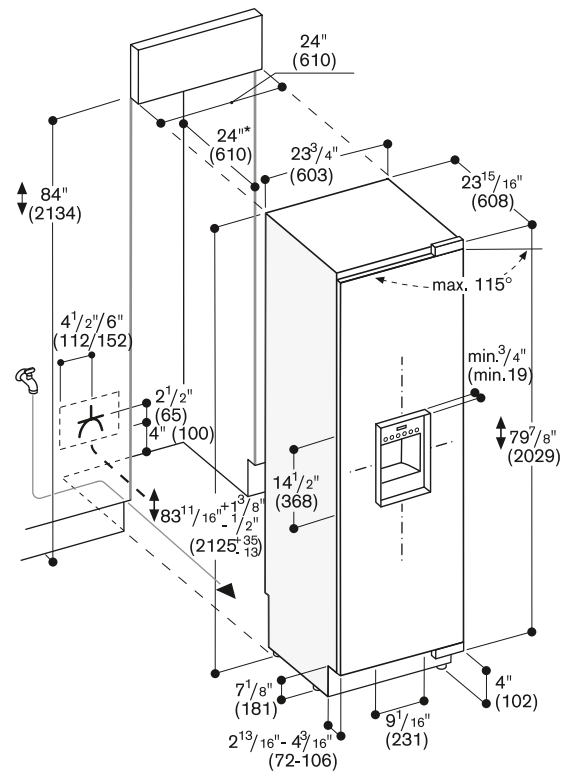

The door face dimensions are designed for a maximum gap of 1/8" (3 mm).
* For a flush-mounted appearance, the minimum cut-out depth must be 25". See more details on pages 170 and 177.

RF 463 702

Fully integrated with ice and water dispenser
Right-hinged
width 24"

RF 463 703

Fully integrated with ice and water dispenser
Left-hinged
width 24"

Required installation accessories

RA 460 010

Heating kit if columns are not attached (in separate niches) and less than 6" apart

Installation accessories

RA 422 610

Stainless steel door panel with handle for RF 463
Panel thickness 3/4".

RA 450 010

Activated charcoal filter for water filter system including saturation indication.

RA 425 110

Long stainless steel handle, length 44 1/2", with three brackets, drilling distance between each mount 21 13/16"

RA 460 020

Connecting element for vertically split appliance fronts (for a flush front)

RA 461 614

Ventilation grill
Stainless steel, for RF 463, right-hinged.

RA 461 615

Ventilation grill
Stainless steel, for RF 463, left-hinged.

RA 460 000

Installation kit for side-by-side installation (for connecting any two columns) Side-by-side kit comes already attached to all RF freezers and RW wine units



Numbers indicated inside parenthesis () = mm