



200 series two-door bottom freezer
RB 280

- Three climate zones including fresh cooling
- Height adjustable safety glass shelves
- Door racks with aluminum profiles
- Innovative defrost technology:
 - Reduced energy consumption due to new evaporator design
 - Faster defrosting and easier cleaning due to less severe and more uniform ice build-up
 - Safety glass shelf between freezer drawers
- Soft-closing system for a controlled door closure
- Total unit gross capacity 9.6 cu.ft.
- ENERGY STAR® certified

Operation

Electronic precision temperature control with digital temperature display. Touch keys.

Technical Features

Soft-closing door system from 20° door opening angle, integrated in door hinge.

Open-door and malfunction warning system.

Energy-saving vacation mode.

Home network integration for digital services (Home Connect) wireless via WiFi.

For further information please check: home-connect.com.

Cooling compartment

Gross capacity 6.7 cu.ft.

Fast cooling.

Automatic defrosting with defrost water evaporation.

Temperature adjustable from 35 °F to 46 °F (+2 °C to +8 °C).

5 safety glass shelves, of which 1 is fully extendable and 4 are height adjustable.

1 large door rack with aluminum profile for bottles with flexible bottle holder.

4 door racks with aluminum profile.

1 vegetable drawer.

Bright interior lighting with integrated glare-free side light elements.

1 full-width humidity drawer for vegetables, manually controllable.

Freezer compartment

Gross capacity 3 cu.ft.

No-frost technology with fast freezing.

Temperature adjustable from 3 °F to -11 °F (-16 °C to -24 °C).

Defrost assistance.

3 freezer drawers, 1 of which extra large.

2 safety glass shelves.

Planning notes

Flat hinge.

Door hinge right, reversible.

Door opening angle of 115°, optional 90° door stop.

Max. door panel weight:

Upper door: 40 lb.

Drawer: 40 lb.

Consumption data

Energy consumption

394 kWh/year.

Noise level 39 dBA.

Rating

Total rating 1.081 kWh/24 h.

Total Amps: 10 A.

120 V / 60 Hz

Connecting cable 90" with plug.

RB 280 704

Two-door bottom freezer without ice maker fully integrated
 Width: 22 1/4" (56 cm)

Included accessories

- 2 ice cube trays
- 2 ice packs
- 2 egg trays

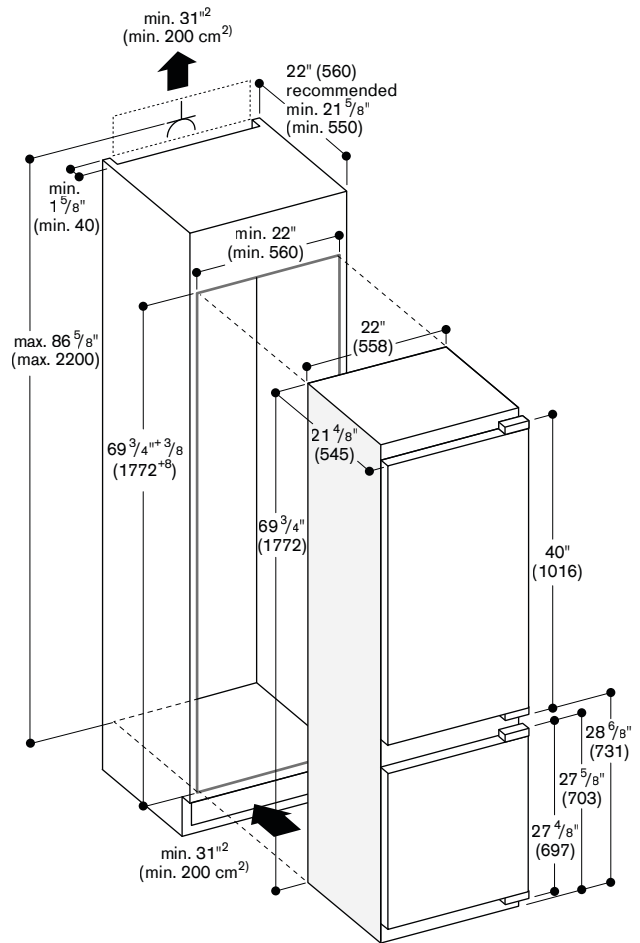

Numbers indicated inside parenthesis () = mm