



200 series two-door bottom freezer
RB 280

- Three climate zones including fresh cooling
- Height adjustable safety glass shelves
- Door racks with aluminum profiles
- Innovative defrost technology:
 - Reduced energy consumption due to new evaporator design
 - Faster defrosting and easier cleaning due to less severe and more uniform ice build-up
 - Safety glass shelf between freezer drawers
- Soft-closing system for a controlled door closure
- Total unit gross capacity 9.6 cu.ft.
- ENERGY STAR® qualified

RB 280 703

Two-door bottom freezer
 without ice maker
 fully integrated
 Width: 22 1/4" (56 cm)

Included accessories

- 2 ice cube trays
- 2 ice packs
- 2 egg trays



Operation

Electronic precision temperature control with digital temperature display.
 Touch keys.

Technical Features

Soft-closing door system from 20° door opening angle, integrated in door hinge.
 Open-door and malfunction warning system.
 Energy-saving vacation mode.

Cooling compartment

Gross capacity 6.7 cu.ft.
 Fast cooling.
 Automatic defrosting with defrost water evaporation.
 Temperature adjustable from 35 °F to 46 °F (+2 °C to +8 °C).
 5 safety glass shelves, of which 1 is fully extendable and 4 are height adjustable.
 1 large door rack with aluminum profile for bottles with flexible bottle holder.
 4 door racks with aluminum profile.
 1 vegetable drawer.
 Bright interior lighting with integrated glare-free side light elements.
 1 full-width humidity drawer for vegetables, manually controllable.

Freezer compartment

Gross capacity 3 cu. ft.
 No-frost technology with fast freezing.
 Temperature adjustable from 3 °F to -11 °F (-16 °C to -24 °C).
 Defrost assistance.
 3 freezer drawers, 1 of which extra large.
 2 safety glass shelves.

Planning notes

Flat hinge.
 Door hinge right, reversible.
 Door opening angle of 115°, optional 90° door stop.
 Max. door panel weight:
 Upper door: 40 lb.
 Drawer: 40 lb.

Consumption data

Energy consumption 1.081kWh/24 h;
 annually: 394 kWh
 Noise level 39 dBA.

Rating

Total rating 0.09 kW.
 Total Amps: 10 A.
 120 V / 60 Hz
 Connecting cable 90" with plug.

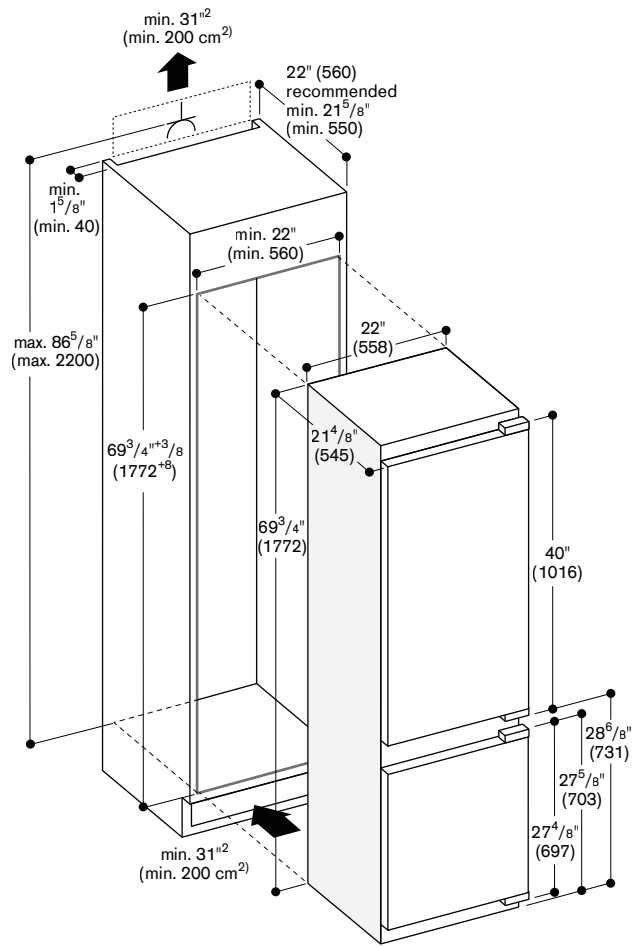

Numbers indicated
 inside parenthesis () = mm