



EB 333 610*

Stainless steel
Width 36" (90 cm)

*Available Spring 2017

Included accessories

- 1 baking tray, pyrolytic-safe enamel
- 1 rotisserie spit
- 1 wire rack
- 1 broiling tray with wire rack
- 1 meat probe

Optional accessories

BA 090 100

Black control knobs, set of 2.

BA 018 105

Pull-out system
Enameled cast-iron frame and fully extendable telescopic rails.

BA 028 115

Baking tray, enameled
3/8" deep.

BA 038 105

Wire rack, chromium-plated
Offset rack, no opening.

BA 058 115

Heating element
Necessary accessory for baking stone
BA058133 and Gastronorm roaster
GN340230.

BA 058 133

Baking stone
With support and pizza peel (heating element must be ordered separately).
Not in combination with pull-out system.

BS 020 002

Pizza peel, additional set of 2.

GN 340 230

Gastronorm roaster
Non-stick cast-aluminum
4" deep, with 2 1/2" lid, GN 3/4.

Single oven

EB 333

- One-piece front-hinged door with 3 mm precision crafted stainless steel front door panel
- Soft door opening and closing system
- Diagonally positioned light sources for optimal interior lighting
- Pyrolytic self-cleaning
- Universal heating system with 17 heating modes, with meat probe, rotisserie spit and baking stone operation
- Convection fan rotates in both directions for ideal heat distribution
- TFT touch display
- Panel-free appliance with control module behind glass
- Electronic precision temperature control from 85°F to 550°F
- 3.6 cu.ft. net volume

Cooking modes

Convection.
Economy convection.
Top + bottom heat.
Top + 1/3 bottom heat.
Top heat.
1/3 top + bottom heat.
Bottom heat.
Convection + bottom heat.
Convection + 1/3 bottom heat.
Convection broiling.
Broiling.
Compact grill.
Baking stone operation.
Roaster function.
Dough proofing.
Defrosting.
Keeping warm.

Operation

Rotary knobs and TFT touch display operation.
Clear text display in 25 languages.
Option to save individual recipes (incl. meat probe).
Information key with use indicators.
Front-hinged door with 90° door opening angle.

Features

Meat probe with automatic shut-off function.
Rotisserie spit.
Baking stone outlet.
Actual temperature display.
Super-quick preheating.
Timer functions: cooking time, switch-off time, short-term timer, stopwatch.
60 W halogen light on the top.
2 x 10 W halogen light on the side.
Enameled side shelf supports with 3 rack levels, pyrolytic-safe.

Safety

Thermally insulated door with quintuple glazing.
Child lock.
Safety lock.
Cooled housing with temperature protection.

Cleaning

Pyrolytic self-cleaning.
Gaggenau Clean-Enamel.
Heated air cleaning catalyst.

Planning notes

The door panel surface of the appliance extends 1 9/16" (40 mm) from the cabinet front.
The outer edge of the door handle extends 3 9/16" (90 mm) from the cabinet front.
For installation underneath cooktops: Distance between the underside of the cooktop and the top edge of the oven cavity: min. 1 9/32" (15 mm). The planning notes for the cooktops (particularly regarding ventilation, gas/electric connection) must be taken into account.
To achieve the 21 5/8" (550 mm) installation depth, the connection cable needs to follow the slanted edge on the corner of the housing.
Plan a power outlet outside of the cut-out niche.

Rating

Total rating 5.9 kW.
Total Amps: 25 A.
208/220 - 240 V / 60 Hz
Connection cable 47 1/4" without plug (hardwire required).

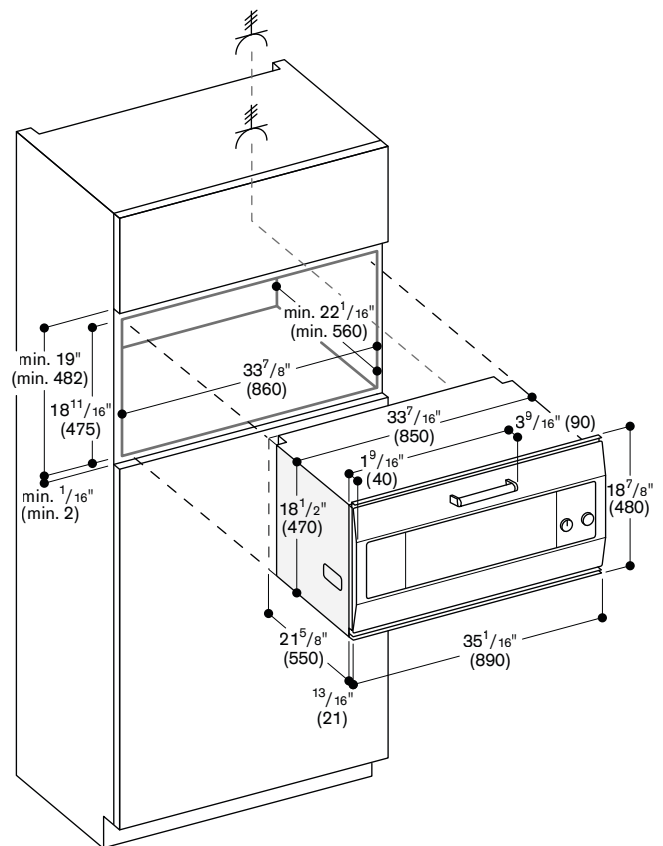

Numbers indicated
inside parenthesis () = mm