



#### CX 491 610

Stainless steel frame  
Width 36" (90 cm)

#### Installation accessories

In combination of several Vario cooktops, connecting strips must be used.

Choose respective VA 420 strip from one of the below, depending on type of installation.

#### VA 420 010

Connection strip for **surface-mount** installation **without** appliance cover.

#### VA 420 011

Connection strip for **surface-mount** installation **with** appliance cover.

#### VA 420 000

Connection strip for **flush** installation **without** appliance cover.

#### VA 420 001

Connection strip for **flush** installation **with** appliance cover.

#### VA 450 900

36" stainless steel adjustment strip. Necessary accessory in a combination of 15" Vario(s) with at least one cover adjacent to a 36" cooktop. VA 450 strip will compensate the appliance depth.

#### Optional accessories

#### GN 232 110

Teppan Yaki plate made of multi-ply material, 13" x 21".

#### GN 232 230

Teppan Yaki plate made of multi-ply material, 13" x 14".

#### GN 340 230

Gastronorm roaster  
Non-stick cast-aluminum  
4" deep, with 2 1/2" lid, GN 3/4

#### GP 900 001

Stainless steel 6" frying pan  
Non-stick cooking.

#### GP 900 003

Stainless steel 8" frying pan  
Non-stick coating.



product  
design  
award

2011 ■

#### Full surface induction cooktop

#### CX 491

- One large cooking surface
- Free positioning of cookware
- Cookware of any shape and size can be used
- TFT touch display for an intuitive control of all functions
- Max. power output for large cookware of up to 4,600 W with Power boost function
- Precision-crafted 1/8-inch stainless steel frame
- For surface-mount installation with a visible edge or for flush installation
- Can be perfectly combined with other Vario 400 series products

#### Cooking zones

One unique cooking surface allows for cookware as small as 3" and as large as 13" x 21".

Up to 4 items of cookware can be placed simultaneously on the cooktop.

#### Operation

Large 6.5" color graphic TFT touch display with an easy-to-use display concept.

Electronic power control in 17 output levels.

#### Features

Power boost function.  
Individual pot detection.  
Timer for each cooking position.  
Short-term timer.  
Information key with use indicators.  
Power management.

#### Safety

Main switch.  
Residual heat indicator.  
Child lock.  
Display cleaning protection.

#### Planning notes

Depending on the type of installation (surface-mounted or flush-mounted), the specific definition of the cut-out must be observed.

When using the appliance cover VA 440 or adjustment strip VA 450 additional space for cut-out depth needs to be considered.

In a combination of Vario cooktops with at least one appliance cover, the adjustment strip VA 450 is required. In a combination of several Vario 400 series cooktops a connection strip must be used.

Depending on the type of installation—surface- or flush-mounted, with or without cover—the respective VA 420 connecting strip must be used.

For flush installation the edge height in the cut-out needs to be at least 1/2" and for surface-mount 3/8". Ensure a continuous cut surface of 90°.

The weight capacity and stability, especially in case of thin countertops, must be supported using suitable substructures. Take the appliance weight and additional loads into account.

Flush installation is possible in countertops made of stone, synthetics or solid wood. Heat resistance and watertight sealing of the edges must be observed. For other materials, please consult with your countertop manufacturer.

The groove must be continuous and even, so that uniform placing of the appliance on the gasket is ensured. Do not use discontinuous lining.

Operates with magnetic (induction) iron pots and pans only. For an optimal heat distribution, the use of sandwich bottom cookware is recommended. Immersion depth depending on installation situation, 3 3/8" for surface-mount or 3 5/8" for flush-mount. Intermediate shelf is required. Appliance can be snapped into the countertop from above.

Please read additional planning notes on combinations with Vario 400 series cooktops on pages 82 – 87.

Please read the installation details regarding air ducting on page 121.

#### Rating

Total rating: 7.2 kW.

Total Amps: 40 A.

208/220–240 V / 60 Hz

Plan for a 37" connecting cable without plug (hardwire required).

## Surface-mount Installation

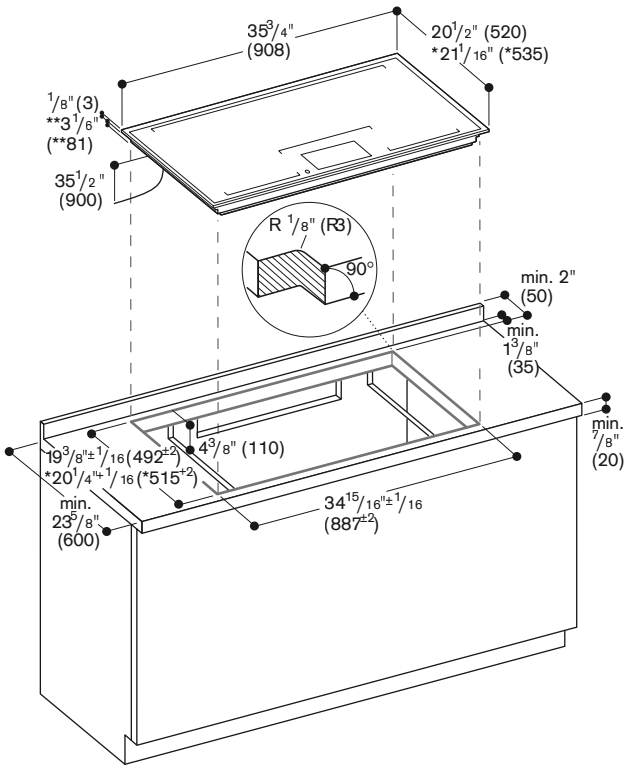

\* with adjustment strip. See separate planning notes on page 87.  
 \*\* Recessed depth in the vicinity of the electrical connection box:  $4\frac{1}{16}''$ .

## Flush-mount Installation

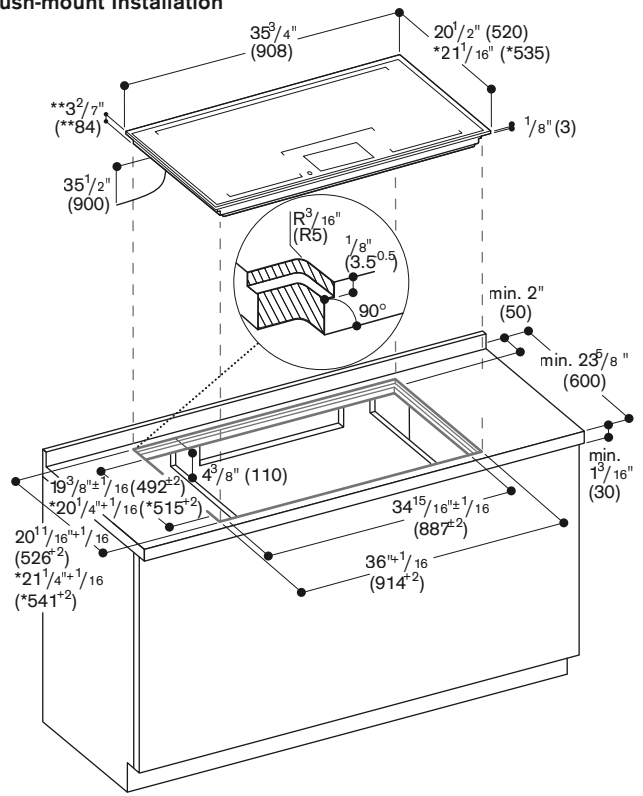

\* with adjustment strip. See separate planning notes on page 87.  
 \*\* Recessed depth in the vicinity of the electrical connection box:  $4\frac{3}{8}''$ .

## View from above

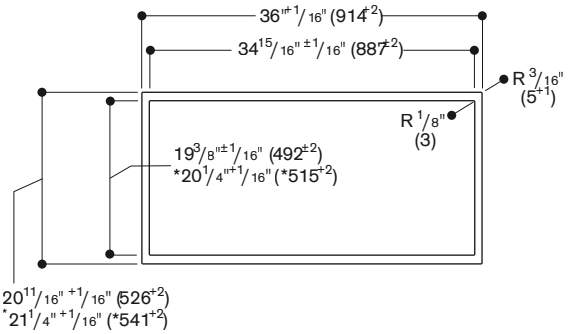

\* with adjustment strip

## Longitudinal section

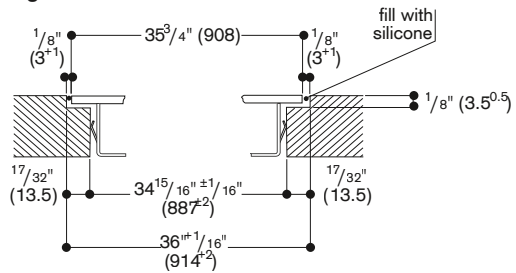

## Cross-section

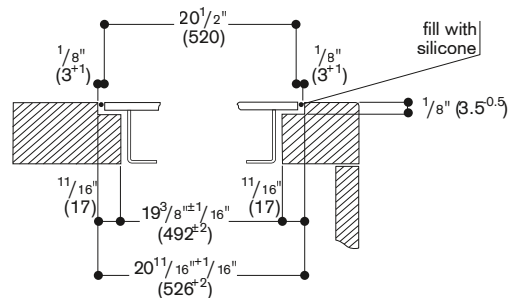

When installing with appliance cover or adjustment strip, pay attention to the deeper cut-out and the front and rear groove width.

Numbers indicated inside parenthesis ( ) = mm