

CI 292 600*
Frameless
Width 36" (90 cm)

*Available Spring 2017

Included accessories

CA 060 600
Cooking sensor for temperature regulation within pots.
For flex induction cooktop.

Optional accessories

CA 051 300
Teppan Yaki made of multi ply material
For flex induction cooktop.

GP 900 001

Stainless steel frying sensor pan
Non-stick coating, for ø 6" cooking zone.

GP 900 002

Stainless steel frying sensor pan
Non-stick coating, for ø 7" cooking zone.

GP 900 003

Stainless steel frying sensor pan
Non-stick coating, for ø 8" cooking zone.

GP 900 004

Stainless steel frying sensor pan
Non-stick coating, for ø 11" cooking zone.

Flex induction cooktop

CI 292

- Frameless for flush mounting
- Flex function for combining the rectangular cooking areas
- Free positioning of cookware inside combined cooking areas
- Cooking sensor function for temperature control in pots
- Frying sensor function for temperature control in pans
- Large cooking zone for pots up to ø 13"
- Twist-Pad control—the maneuverable magnetic knob sets cooking zone and temperature
- Easy control of all functions with bi-colored display

Cooking zones

2 flex induction cooking areas 7 1/2" x 9" (2,200 W, with Power boost 3,700 W), linked together 15" x 9" (3,300 W, with Power boost 3,600 W).
1 induction cooking zone ø 9" (3,300 W, with Power boost 3,700 W), automatically switches to ø 10" (2,600 W, with Power boost 3,700 W) and to ø 13" (2,200 W, with Power boost 3,700 W).

Operation

Twist-Pad control with removable magnetic knob.
User friendly control with bi-colored display (white / orange).
Cooking zone, and cooking area marking.
Electronic power control in 17 output levels.

Features

Flex function for rectangular cooking areas.
Cooking sensor function (in use with cooking sensor CA 060 600).
Frying sensor function.
Booster function for pots.
Booster function for pans.
Keep warm function.
Stopwatch.
Cooking timer for up to 99 minutes.
Short-term timer.
Memory function.
Options menu.
Power management.

Safety

Main switch.
Operation indication.
Pan detection.
2-stage residual heat indication.
Child lock.
Safety shut-off.

Planning notes

Operates with magnetic (induction) iron pots and pans only. For an optimal heat distribution, the use of sandwich bottom cookware is recommended. The wok pan WP 400 001 cannot be used with this appliance.
Immersion depth depending on installation situation, 2 5/8" for surface-mount or 2 3/4" for flush-mount. Intermediate shelf is recommended. Appliance must be fixed from underneath.

Cooktop clamping range:
1 3/16" – 1 9/16".

Appliance weight: approx. 40 lbs.

Please read additional planning notes on page 123.

Rating

Total rating: 11.1 kW
Total Amps: 45 A.
208/220–240 V / 60 Hz
Connecting cable 60" without plug (hardwire required).

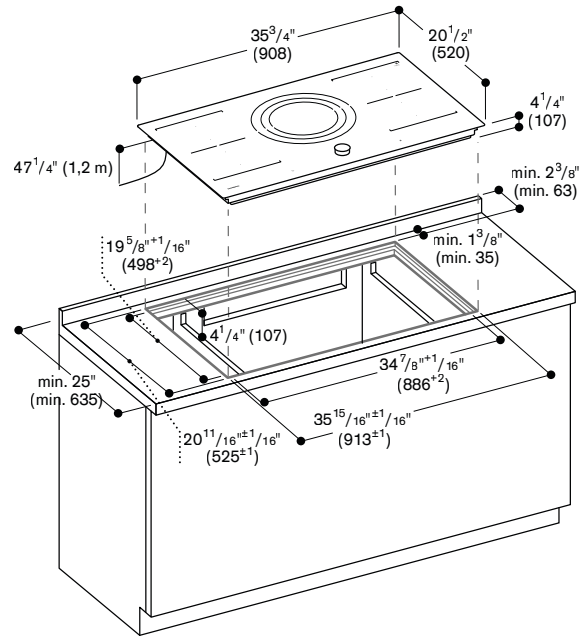

View from above

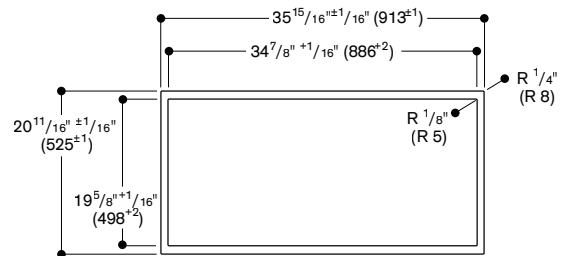

Longitudinal section

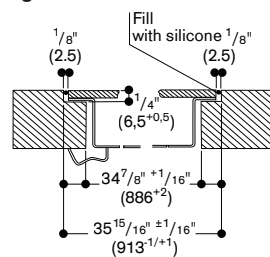

Cross-section

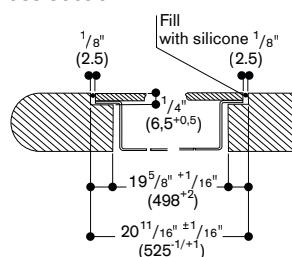

Numbers indicated inside parenthesis () = mm